



ClayTech SlimSub Automatic Submersible Multi-Stage Pressure Pump

812314 / SLIMSUB



2. Introduction

Thank you for choosing the ClayTech SLIMSUB PUMP

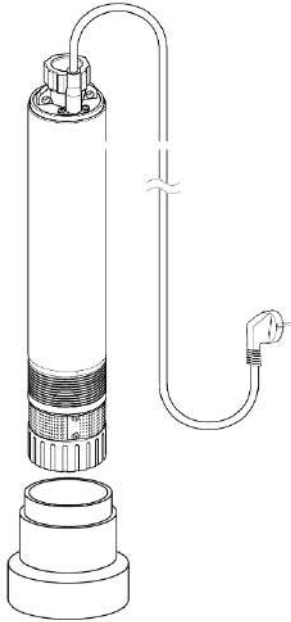

The ClayTech SLIMSUB submersible multistage pump is specially designed and manufactured for use in tanks which have a narrow or restricted opening.

Installed inside the rainwater tank, the submersible design ensures the pump installation is neat, secure and quiet with no requirement to install additional protection against the elements.

It is intended for use in household applications for the automatic supply of clean water which contains no fibres.

The pump has an inbuilt 'pressure controller' and is equipped with a flexible float for additional dry run / low water level protection.

For best results, fit a small (3L) pressure vessel





Applications:

- Drinking Water – AS/NZS4020 drinking water approved
- Household water supply / Pressure boosting
- Gardening / light irrigation





3. Contents

1. Quick installation guide	Error! Bookmark not defined.
2. Introduction.....	2
3. Contents.....	2
4. Warnings	3
5. Symbols used in this manual.....	3
6. Technical information	4
7. Electrical Connections.....	5
8. Installation	Error! Bookmark not defined.
9. Operation.....	7
10. Maintenance and Cleaning.....	7
11. Trouble Shooting.....	8
12. Warranties – Terms and Conditions	9

4. Warnings

	<p>Read the manual carefully before starting. Failure to follow instructions may result in personal injury and may invalid warranty</p>
	<p>This pump is not intended for use in basements, underpass or general drainage applications</p>
	<p>Any changes or modification to the wiring must be carried out by suitably qualified personnel. If the appliance or the supply cord is damaged, it must be repaired by manufacturer, its service agent or qualified person.</p>
	<p>A qualified electrician should correctly size and install circuit breakers to protect the power supply. The fitment of additional surge protection is recommended. Australian Electrical Regulations 2002 state this MUST include an IM = 30mA safety switch</p>
	<p>This pump is not intended for use by persons (including children) with reduced physical, sensory or mental capabilities, or lack of experience and knowledge, unless they have been given supervision or instruction concerning use of the appliance by a person responsible for their safety. Children should be supervised to ensure that they do not play with the appliance.</p>

5. Symbols used in this manual

	<p>Warning - Electrical safety</p>
	<p>Warning – Potential consequences of use outside of intended application(s). Includes environmental condition warnings.</p>
	<p>Mandatory warning</p>
	<p>Warning to disconnect power</p>
	<p>Read carefully</p>

6. Technical information

	SlimSub
P2 Rated Power [W]	650W
Rated voltage	220V-240V
Rated current	4.5A @ 230V
Capacitor	15uF 450V
Motor	Heavy Copper windings with auto resetting thermal overload
Motor Protection Level	Class B insulation IP68
Outlet	1" BSPF
Power Cable	H07RN-F, 10m long
Maximum submergence	7 meters (Pressure rated to 20m)
Working Temperature	Water : 3°C to 35° C
Max. Dia. of Particle	Slotted Strainer – Max 1.5mm particles
Packaging gross weight (kg)	11 kg
Max. Flow [l/min]	85 l/min
Max. Head [m]	48m
Pump Control and Protection	Inbuilt Control + flexible float switch
Start pressure	2.5 bar. Inbuilt check valve and dry run protection

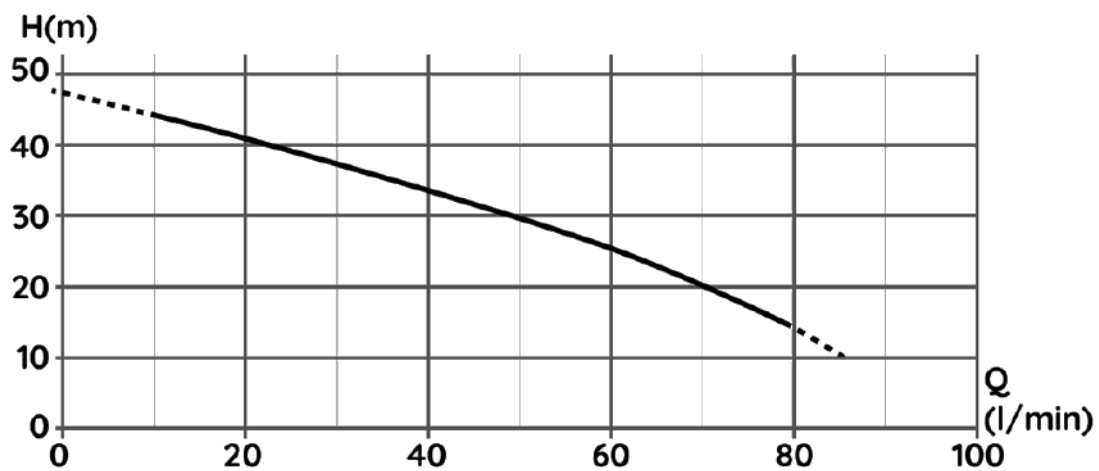

Most domestic applications find 2.0 – 4 bar pressure sufficient.

7. Electrical Connections



Avoid handling the water pump unless the power supply has been isolated.



The pump should be grounded to prevent electrical leakage and should be equipped with a leakage protection switch with a protection current not exceeding 30mA.

1. All electrical connection(s) and protection(s) should be carried out in accordance with local regulations.
2. The electrical specifications are marked on the nameplate. Please ensure that the motor matches the power supply voltage.
3. If the pump is installed some distance from the power supply, the power supply cabling should be sized appropriately to avoid voltage drop.
4. Ensure that all electric cables outside of the device are protected from damage (e.g. caused by animals). Never use the device if electric cables or the power connection are damaged!
5. If the pump is used outdoors, suitable dedicated rubber power supply cable must be used.
6. Never use the cord to lift or drag the pump
7. Avoid damage to the power cord. Should damage occur, do not use the pump. It should be repaired or replaced by professional or authorized personnel.
8. Note that the length of the pump's power cord is intended to limit the pump submersion depth of the pump.
9. The pump is not allowed to be used in occasions where people are in the water.
10. Ensure sure that the plug and socket of the plug cord are kept dry.

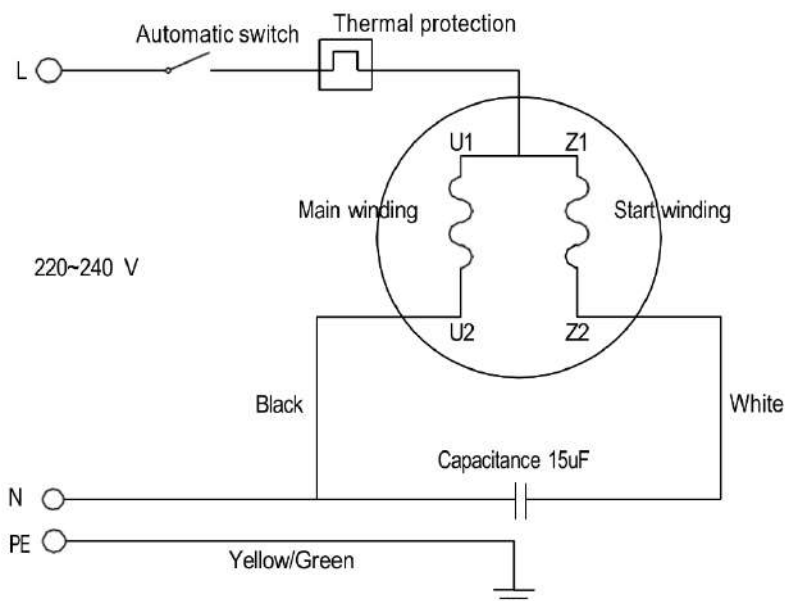

8. Installation

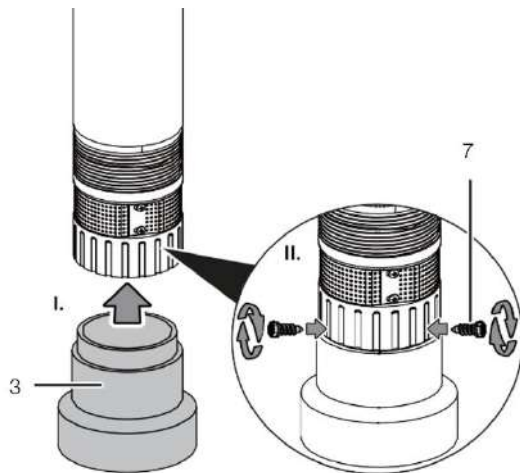

Fitting the spacer foot (3) ensures the inlet screen is raised reducing the risk of ingesting contaminants. The foot must be attached to the device prior to initial start-up.

To do so, proceed as follows:

1. Insert the spacer foot (3) into the bottom side of the device.
2. Screw the spacer foot (3) to the bottom side of the device by using the supplied screws (7).

Only operate the device in an upright position.

The pump location must have an edge length / diameter of at least 125mm.

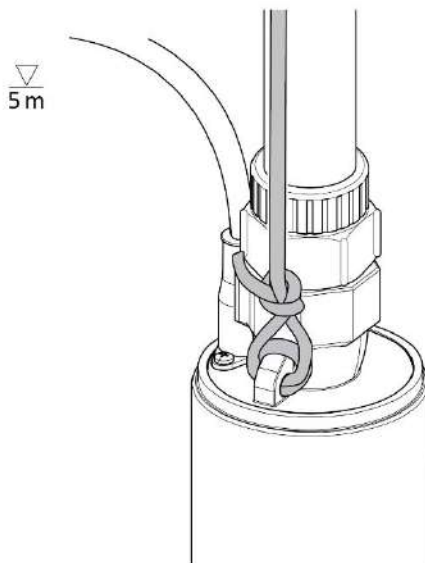

The pump must be tied with a rope to the handle before it can be submerged in the water.

The pump takes about 60 seconds to vent after submersion in the water for first use. Air will exit the pump via the bleed holes.

To minimise the risk of ingesting impurities, such as cement fines or organic matter, install using the support foot to lift the the pump inlet higher into the stored water

The pump will give best life operated fully submerged. A water level less than 200mm higher than the inlet strainer increases the risk of ingesting air

1. Tie the fastening rope to the pump handle
2. Immerse the water pump vertical with the fastening rope
3. Secure the fastening rope and the pump
4. Insert the power cord into the socket and turn on the power



Avoid using the power cable to hang or lift the pump.

Avoid running the pump in a no-load condition.

9. Operation

The ClayTech SlimSub is equipped with an internal check valve and sensor/mechanism to automatically control the start and stop of the water pump.

The flexible float switch provides additional low water level run protection to prevent the pump operating with insufficient water.

1. Normal start:

The pump starts when the pumps senses the pressure in the system has fallen to the preset activation pressure.

Note, the pump does not start immediately when a tap is opened, there is a delay as system pressure falls to 2.5 bar.

Once all taps are closed the pump will sense that the flow has ceased. The pump will continue to run for an additional 10 seconds before shutting down.

2. No-load / Dry run protection:

3. The pump switches off automatically when there is no fluid pumped. The pump first tries up to 4 times in cycles Off for 30 secs, On for 5 secs.

This cycle is repeated in 1 hr, 5 hrs, 24 hrs)

If necessary, cycling the power off and on will reset the pump after ensuring the strainer of the pump is submersed at least 20cm in the water

The motor is cooled by the water pumped. **For continuous running, the pump should be at least half (50%) submerged.**

For best service life, pump starts should not exceed 20 starts per hour evenly spaced.

Current draw, and therefore energy consumption, is significantly higher at the time of the pump starting so reducing the amount of times a pump 'cycles' will extend its life expectancy AND save energy .

To avoid frequent and unnecessary pump restarts, to achieve greater energy savings and ensure correct operation, it is important to install a small pressure tank on the delivery line. A 3, 8 or 18 litre pressure tank is sufficient in a domestic situation.



Set pressure tank precharge to 66% of the max system pressure

i.e $4.8 \text{ bar} \times 0.66 = 3.15 \text{ bar}$

10. Maintenance and Cleaning

Under normal operating conditions, the CLA SLIMSUB pump does not require any special maintenance. Any clogging of the inlet filter screen will restrict performance and may result in harm to the pump

Removal of the water pump must be carried out by professionals. In every case, all repairs and maintenance work must be carried out with the power supply isolated.

11. Trouble Shooting



Before inspecting the pump, disconnect the power supply (i.e. remove the plug from the socket).



White International is not responsible for the consequences of any unauthorized repairs and changes.

If the supply cord is damaged, the pump should be returned to White International or one of its Authorised Service Agents (contact www.whiteint.com.au or www.whiteint.co.nz) for repair in order to avoid potential injury/electrical shock.

To ensure safety, the spare parts used for repair must be original parts provided by the manufacturer or spare parts provided by White International

	Possible cause	Potential Solution
The motor does not start and there is no noise;	Check the power supply to the pump; Inspect check valve for correct installation or blockage; Ensure there is sufficient water for the flexible float to be in its upward 'On' position	Check power supply fuses/circuit breakers Ensure that the check valve is installed correctly and is not blocked;
The pump will not start correctly but makes a noise	Possible partial blockage; Capacitor failure	
Pump flow rate is poor	Clogged water inlet screen Blocked or damaged impellers; The installation head requirement exceeds the pump potential The water demand is excessively high	Clear the blockage; Remove obstacles or replace the impellers
Water doesn't flow when a tap is closed and reopened	Inspect the check valve for blockage	Reinstall the check valve to ensure that there is no blockage;
The flow has decreased over time	Partial blockage of the water inlet screen; The impeller is partially blocked or the outlet pipe is partially blocked;	Remove obstacles
The pump runs for a period of time then switches off unexpectedly.	The thermal overload protection device may have operated to stop the water pump automatically.	The fluid density or fluid temperature may be too high causing the motor to overheat: A small water demand may be causing the pump to start and stop excessively
The pump starts excessively	There is an intermittent small water demand or leak in the pressure system	Ensure a pressure tank is fitted on the delivery line and check the pre-charge to ensure the tank is in good condition

12. Warranties – Terms and Conditions

This warranty is given in addition to the consumer guarantees found within the Australian Competition and Consumer Act 2010 (Cth) for goods purchased in Australia and the Consumer Guarantees Act 1993 NZ for goods purchased in New Zealand:



1) White International Pty Ltd / White International NZ Ltd (White International) warrant that all products distributed are free from defects in workmanship and materials, for their provided warranty period as indicated on the top or opposite side of this document. Subject to the conditions of the warranty, White International will repair any defective products free of charge at the premises of our authorised service agents throughout Australia and New Zealand if a defect in the product appears during the warranty period. If you believe that you have purchased a defective product and wish to make a claim under this warranty, contact us on our Sales Hotline on 1300 783 601, or send your claim to our postal address or fax line below and we will advise you as to how next to proceed. You will be required to supply a copy of your proof of purchase to make a claim under this warranty.

2) This warranty excludes transportation costs to and from White International or its appointed service agents and excludes defects due to non-compliance with installation instructions, neglect or misuse, inadequate protection against the elements, low voltage or use or operation for purposes other than those for which they were designed. For further information regarding the suitability of your intended application contact us on our Sales Hotline on 1300 783 601. If you make an invalid claim under this warranty, the original product will be sent back to you unrepai red.

3) This warranty refers only to products sold after the 1st January 2022, and is not transferable to another product type and only applies to the original owner, purchaser or end user, and is in addition to the consumer guarantees found within the Competition and Consumer Act 2010 (Cth) for goods purchased in Australia and the Consumer Guarantees Act 1993 (NZ) for goods purchased in New Zealand.

4) Our goods come with guarantees that cannot be excluded under the Australian Consumer Law. You are entitled to a replacement or refund for a major failure and for compensation for any other reasonably foreseeable loss or damage. You are also entitled to have the goods repaired or replaced if the goods fail to be of acceptable quality and the failure does not amount to a major failure. 2 YEAR WARRANTY.

5) To the fullest extent permitted by law, White International excludes its liability for all other conditions or warranties which would or might otherwise be implied at law. To the fullest extent permitted by law, White International's liability under this warranty and any other conditions, guarantees or warranties at law that cannot be excluded, including those in the Competition and Consumer Act 2010 (Cth), is expressly limited to: (a) in the case of products, the replacement of the product or the supply of equivalent product, the payment of the cost of replacing the product or of acquiring an equivalent product or the repair of the product or payment of the cost of having the product repaired, is at the discretion of White International or a 3rd party tribunal elected under the Competition and Consumer Act 2010 (Cth) for goods purchased in Australia and the Consumer Guarantees Act 1993 (NZ) for goods purchased in New Zealand; and

6) To the fullest extent permitted by law, this warranty supersedes all other warranties attached to the product or its packaging.

7) In the case of services, supplying the services again or the payment of the cost of having the services supplied again, is at the discretion of White International or a 3rd party tribunal elected under the Competition and Consumer Act 2010 (Cth) for goods purchased in Australia and the Consumer Guarantees Act 1993 (NZ) for goods purchased in New Zealand. 8) Our warranty commences from the date of purchase of the above mentioned pumps. Proof of purchase is required before consideration under warranty is given.

Record your date of purchase in the space below and retain this copy for your records.

Date of Purchase

Model Purchased



www.whiteint.com.au
www.whiteint.co.nz

Please always refer to our website for further technical information & new product innovations

Disclaimer: Every effort has been made to publish the correct information in this manual.
No responsibility will be taken for errors, omissions or changes in product specifications.

© 2025 Copyright White International Pty Ltd

TM ® - WARNING: Please be aware that various brands & products depicted within this document are subject to trademark, patent or design registrations. Infringement of any intellectual property contained within this document without express written authority by the appropriate intellectual property holder may result in further legal action to be taken. For any queries regarding use of the contained information please feel free to contact White International Pty Ltd.